

albs
ALLTRONIC

Customer :

Max-Eyth-Straße 1
D-75443 Otisheim
Telefon: 07041/96160
Telefax: 07041/961616
info@albs.de

Autorisierter
Bauelemente
Distributor von

ALPS®

No. KK-2000-1773

1/10

Date : Oct. 11, 2000

Attention: _____

Your ref. No: _____

Your Part. No : ALBS 20/00 401862

SPECIFICATIONS

ALPS ;

MODEL EC11B1514B

Spec. No. : _____

Sample No. : G5307553M

RECEIPT STATUS
 RECEIVED
 By. Date _____
 Signature _____
 Name _____
 Title _____

ALPS ELECTRIC CO., LTD.

HEAD OFFICE
1-7, YUKIGAYA-OHTSUKA-CHO,
OHTA-KU, TOKYO 145-8501 JAPAN

DSG'D Y. Hatanabe

APP'D S. Aizawa

Sales _____

SPECIFICATIONS

1. THIS SPECIFICATIONS APPLY TO EC11B1514B ENCODER WITH LED

2. CONTENTS OF THIS SPECIFICATIONS.

- LA2114B09
- 4LA211L-04W
- 5LA211-1CL
- 5LA2114-5

3. MARKING

- MARKING ON ALL UNITS
DATE CODE

4. REMARKS

- NOTES

· Marking ⇒ in specifications shows standard and condition for application.

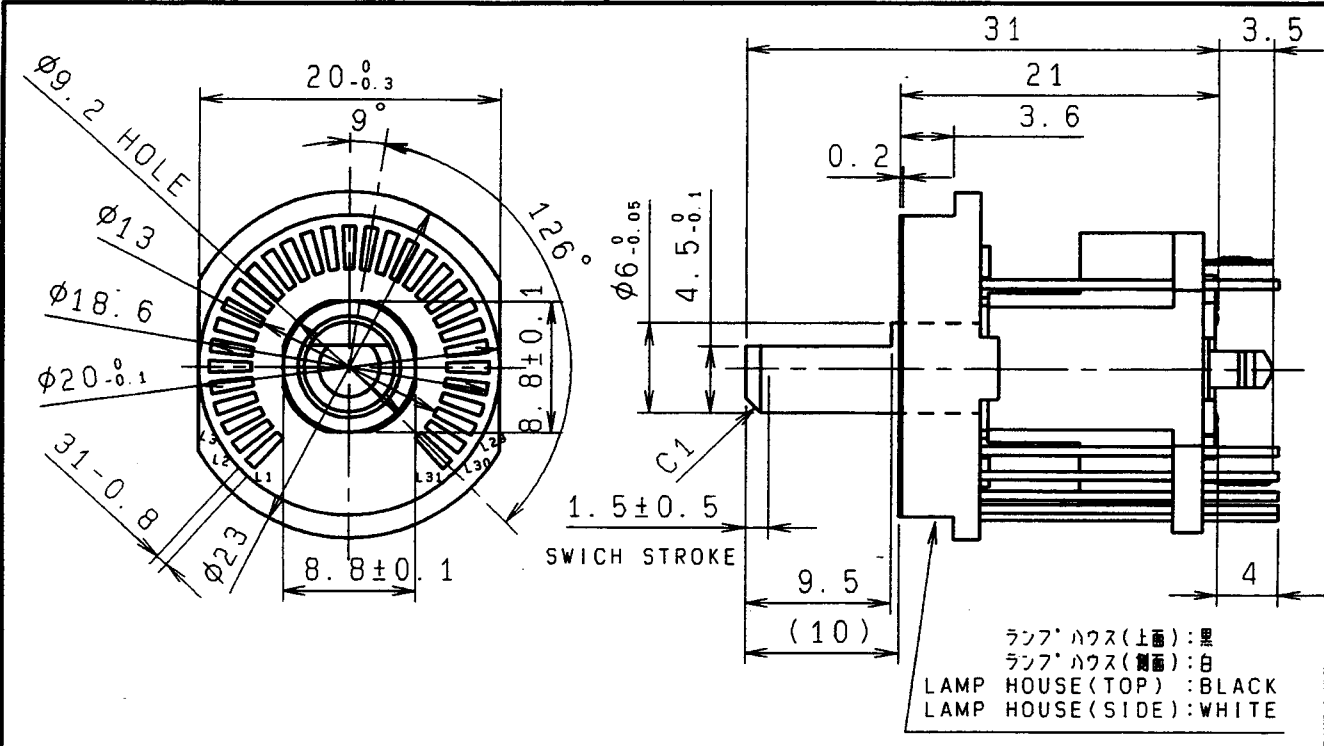

P. W. B. MOUNTING DETAIL (TOLERANCE ± 0.1)
 取付穴寸法図(許容差 ± 0.1)

VIEWED FROM MOUNTING SIDE
 挿入側より見た図

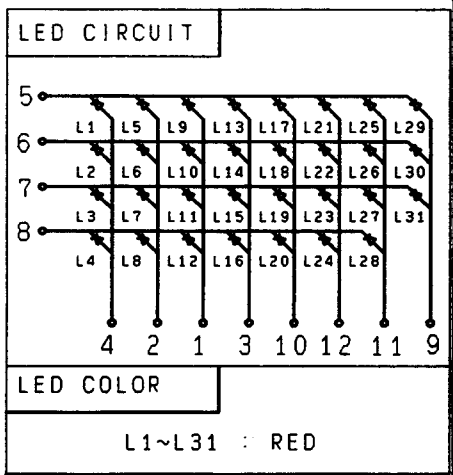
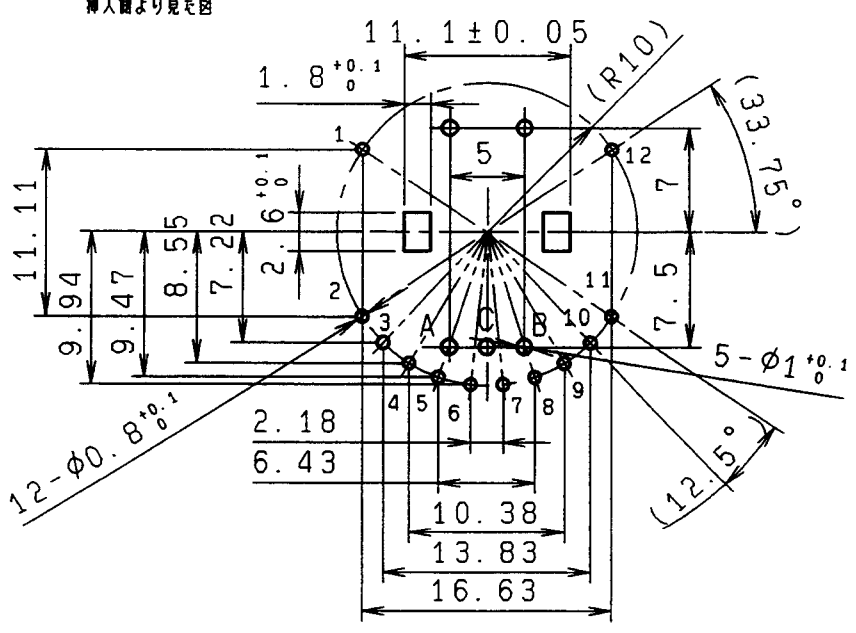

指定なき部分の許容差 TOLERANCES UNLESS OTHERWISE SPEC	
$L \leq 10$	± 0.3
$10 < L < 100$	± 0.5
$100 \leq L$	± 0.8
角度 ANGULAR DIMENSION	$\pm 5^\circ$

				クリック無	
--	--	--	--	-------	--

ALPS ELECTRIC CO., LTD.

DSGD. 1-GROUP2	SCALE	NO.
Y. WATANABE OCT. 11 2000	2 : 1	
CHKD.	UNIT	TITLE
S. ABE OCT. 12 2000		LED ユニット
APPD.	m m	LA2114B09
S. AIZAWA OCT. 13 2000		

LED:赤
 クリック無
 Sw付

SYMB	DATE	APPD	CHKD	DSGD
------	------	------	------	------

OR

発光色 SOURCE COLOR: 赤色 RED

絶対最大定格 Absolute Maximum Rating

(Ta=25°C)

項目 Items	記号 Symbol	最大定格 Maximum Rating	単位 Unit
許容損失 Power Dissipation	P_d	56	mW
尖頭順電流 Peak Forward Current	I_{FM}	*50	mA
逆電圧 Reverse Voltage	V_R	4	V
動作温度 Operating Temperature	T_{opr}	-30 ~ +70	°C
保存温度 Storage Temperature	T_{stg}	-40 ~ +80	°C

注記 1. I_{FM} の条件は、 $Duty \leq 1/4$, $t_w \leq 0.2msec$, $\Delta I_{FM} = 0.89mA/^\circ C$ とする。
 NOTES 1. I_{FM} applies for the condition:
 $t_w \leq 0.2msec$. and duty cycle $\leq 1/4$.
 The current derating for operation above 25°C
 is 0.89mA/°C for Pulse drive.

電氣的, 光学的特性 Electro-Optical Characteristics

(Ta=25°C)

項目 Items	記号 Symbol	条件 Conditions	最小値 Min.	標準値 Typ.	最大値 Max.	単位 Unit
順電圧 Forward Voltage	V_F	$I_F = 20mA$	—	2.0	2.8	V
逆電流 Reverse Current	I_R	$V_R = 4V$	—	—	100	μA
発光光度 Luminous Intensity	I_v	$I_F = 20mA$	0.5	2	8	mcd
ピーク発光波長 Peak Wave Length	λ_D	$I_F = 20mA$	—	630	—	nm
スペクトル半値幅 Spectral Line Half Width	$\Delta\lambda$	$I_F = 20mA$	—	30	—	nm

- 絶対最大定格及び電氣的, 光学的特性は1チップ°当たりの値とする。
- Ratings and specifications are for one segment.
- 1ユニット内の相対光度のバラツキは3倍以内とする。
- As far as the variation of luminous intensity, no dot is 3.0 times brighter than any other dot in one unit.

(推奨回路ブロック図)
Recommended drive circuit Block diagram

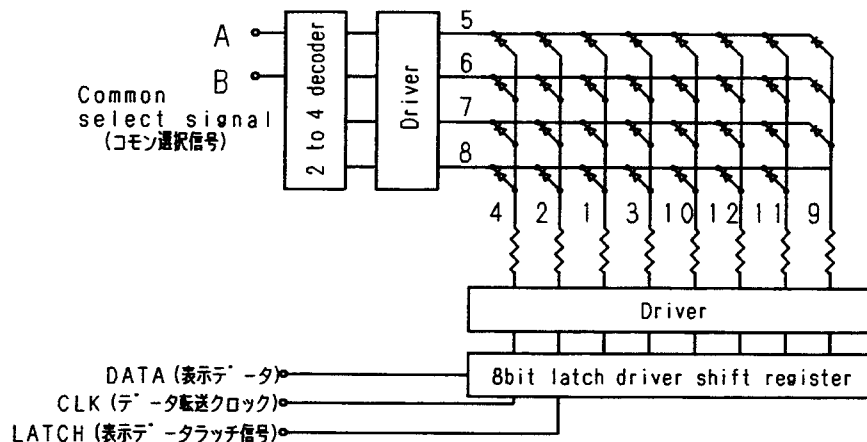

ALPS ELECTRIC CO., LTD.

APPD. Jul. 2 '96
 CHKD. Jul. 2 '96
 DSGD. JUL. 02 '96
 K. YAMAZAKI

TITLE
SPECIFICATION

DOCUMENT NO.
4LA211L-04W

(1/1)

SYMB DATE APPD CHKD DSGD

OR

CLASS No.	TITLE 回転形エンコーダ 規格書 ROTATIONALENCODER SPECIFICATION	(SW01)
-----------	--	--------

1. 一般事項 General

1-1 適用範囲 Scope

この仕様書は主として電子機器に用いる微小電流回路用11形薄形ロータリーエンコーダに適用する。
This specification applies to 11mm size low-profile rotary encoder (incremental type) for microscopic current circuits, used in electronic equipment.

1-2 標準状態 Standard atmospheric conditions

測定は特に指定のない限り、次の状態で行なう。
Unless otherwise specified, the standard range of atmospheric conditions for making measurements and tests is as follows:

- 温度 Ambient temperature : 15°C to 35°C
- 相対湿度 Relative humidity : 25% to 85%
- 気圧 Air pressure : 86kPa to 106kPa

但し、疑義を生じた場合は、次の標準状態で行なう。

If there is any doubt about the results, measurements shall be made within the following limits:

- 温度 Ambient temperature : 20 ± 1°C
- 相対湿度 Relative humidity : 63% to 67%
- 気圧 Air pressure : 86kPa to 106kPa

1-3 使用温度範囲

Operating temperature range : -30°C to +70°C

1-4 保存温度範囲

Storage temperature range : -40°C to +80°C

2. 構造 Construction

2-1 寸法 Dimensions

添付組立図による。
Refer to attached drawing.

3. 定格 Rating

3-1 定格容量

Rating : D. C. 5V 10mA (1mA MIN)

4. 電気的性能 Electrical characteristics

項目 Item	条件 Conditions	規格 Specifications													
4-1 出力信号 Output signal format	<Fig 1>	A, B2信号の位相差出力とし、詳細は<fig. 1>の通りとする。 (破線はクリック付きの場合のクリックの位置を示す。) 2 Phase-different signals (SignalA, signalB) Details shown in <fig.1>. (The broken line shows detent position of with-detent type.)													
		<table border="1"> <thead> <tr> <th>軸回転方向 Shaft rotational direction</th> <th>信号 Signal</th> <th>出力波形 Output</th> </tr> </thead> <tbody> <tr> <td rowspan="2">時計方向 C. W.</td> <td>A (A-C端子間) A(Terminal A-C)</td> <td></td> </tr> <tr> <td>B (B-C端子間) B(Terminal B-C)</td> <td></td> </tr> <tr> <td rowspan="2">反時計方向 C. C. W.</td> <td>A (A-C端子間) A(Terminal A-C)</td> <td></td> </tr> <tr> <td>B (B-C端子間) B(Terminal B-C)</td> <td></td> </tr> </tbody> </table>	軸回転方向 Shaft rotational direction	信号 Signal	出力波形 Output	時計方向 C. W.	A (A-C端子間) A(Terminal A-C)		B (B-C端子間) B(Terminal B-C)		反時計方向 C. C. W.	A (A-C端子間) A(Terminal A-C)		B (B-C端子間) B(Terminal B-C)	
		軸回転方向 Shaft rotational direction	信号 Signal	出力波形 Output											
		時計方向 C. W.	A (A-C端子間) A(Terminal A-C)												
B (B-C端子間) B(Terminal B-C)															
反時計方向 C. C. W.	A (A-C端子間) A(Terminal A-C)														
	B (B-C端子間) B(Terminal B-C)														

7/10/77

ALPS ELECTRIC CO., LTD.

APPD 1枝-2G '99.10.19 伊藤	CHKD 1枝-2G '99.10.19 林	DSGD 1枝-2G 49.11.19 海渡	TITLE ROTATIONAL ENCODER 回転形エンコーダ
DOCUMENT NO.			5LA211-1CL (1/5)

CLASS No.	TITLE 回転形エンコーダ 規格書 ROTATIONAL ENCODER SPECIFICATION	(SW01)
-----------	---	--------

項目 Item	条件 Conditions	規格 Specifications
4-2 分解能 Resolution	1回転にて出力されるパルス数 Number of pulses in 360° rotation.	各相 15パルス/360° 15 pulses/360° for each phase (2クリック1パルス) (2click 1pulse)
4-3 スイッチング特性 Switching characteristics	下記測定回路<fig. 2>を用い、回転軸を360°・s ⁻¹ の速さで回転し測定する。 Measurement shall be made under the condition as follows. 1) Shaft rotational speed : 360°・s ⁻¹ 2) Test circuit : <fig. 2>	
<div style="display: flex; justify-content: space-around;"> <div style="text-align: center;"> <p><fig. 2></p> </div> <div style="text-align: center;"> <p><fig. 3></p> </div> </div> <p>(注記) コードOFF状態 : 出力電圧が3.5V以上の状態を言う。 コードON状態 : 出力電圧が1.5V以下の状態を言う。 (note) Code-OFF area : The area which the voltage is 3.5V or more. code-ON area : The area which the voltage is 1.5V or less.</p>		
1) チャタリング Chattering	コードのOFF→ON及びON→OFFの際の、出力1.5V~3.5Vの通過時間にて規定する。 Specified by the signal's passage time from 3.5V to 1.5V or from 1.5V to 3.5V of each switching position (code OFF→ON or ON→OFF).	$t_1, t_3 \leq 2\text{ms}$
2) 揺動ノイズ (ハ) ウンス Sliding noise (Bounce)	コードONの部分の1.5V以上の電圧変動時間とし、チャタリング t_1, t_3 両者との間1ms以上の1.5V以下のON部分を有するものとする。また、揺動ノイズ間1.5V以下の範囲が1msある場合は、別の揺動ノイズと判断する。 Specified by the time of voltage change exceed 1.5V in code-ON area. When the bounce has code-ON time less than 1ms between chatterings (t_1 or t_3), the voltage change shall be regarded as a part of chattering. When the code-ON time between 2 bounces is less than 1ms, they are regarded as 1 linked bounce.	$t_2 \leq 2\text{ms}$
3) 揺動ノイズ Sliding noise	コードOFFの部分の電圧変動 The voltage change in code-OFF area.	3.5V以上 3.5V MIN

		APPD 1枚-2G '99.10.19 安藤	CHKD 1枚-2G '99.10.19 林	DSGD 1枚-2G '99.10.19 薄淵	TITLE ROTATIONAL ENCODER 回転形エンコーダ DOCUMENT NO. 5LA211-1CL (2/5)
SYMB	DATE	APPD	CHKD	DSGD	OR

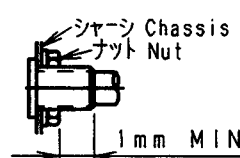
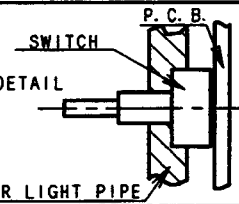
CLASS No.	TITLE 回転形エンコーダ 規格書 ROTATIONALENCODER SPECIFICATION		(SW01)
項目 Item	条件 Conditions	規格 Specifications	
5-6 軸受ネジ締付強度 Bushing nut tightening strength	(ネジ 付きのみ適用) (Applied for with-thread type) <fig. 5>を満足するように締付る。 Tighten the nut according to <fig. 5>	 1N・m以上 1N・m MIN.	
5-7 軸ガタ Shaft wobble	軸先端から5mmの位置に50mN・mの曲げモーメントを加える。 A momentary load of 50mN・m shall be applied at the point 5mm from the tip of the shaft in a direction perpendicular to the axis of shaft.	軸受長 Bushing length (mm)	軸ガタ Wobble (mmp-p less) 以下
		3.5	1.4xL/30
		5	1.1xL/30
		7	0.7xL/30
		Lは取付長さで比例計算する。 L: Measurement point from mounting surface of bushing.	
5-8 軸のスラスト方向ガタ Shaft play in axial direction		0.4mmp-p以下 0.4mmp-p MAX.	
5-9 軸の回転方向ガタ Rotation play at the click position	(クリック付きのみ適用) (Applied for with-detent type) 角度板にて測定する。 Measure with jig for rotational angle.	5度以内 5° MAX.	
5-10 はんだ耐熱 Resistance to soldering heat	7項の「はんだ付け条件」による。 Specified by the clause 7 "Soldering conditions".	絶縁体の変形、破損のないこと。 感熱に異常のないこと。 There shall be no deformation or cracks in molded part. No excessive abnormality in rotational feeling.	
5-11 取付け上の注意 Notice for mounting	右図の様にスイッチ本体を抑えてご使用下さい。セット側でスイッチ本体の引き及び回転方向の「イト」が無い場合は、はんだ付けだけの固定となり、はんだ付け信頼性及びスイッチ本体強度が不安定となる可能性があります。 Hold the bushing use front panel or light pipe. Because this switch not has thread. If don't hold the bushing, the switch maybe become intermittent or rough mounting after soldering by knob stopper face.		

6. 耐久性能 Endurance characteristics.

項目 Item	条件 Conditions	規格 Specifications
6-1 しゅう動寿命性能 Rotational life	無負荷で軸を毎時500サイクルの速さで、15,000回転連続動作を行う。 但し、試験途中5,000で中間測定を行う。(1サイクルは、360°1往復) The shaft of encoder shall be rotated to 15,000 cycles at a speed of 500cycles per hour without electrical load, after which measurements shall be made. However, an interim measurement shall be made immediately after 5,000 cycles. (1 cycle: rotate 360° CCW rotate 360° CW)	回転トルク: 初期規格値に対し+10% -30% その他、初期規格を満足すること。 Rotational torque: Relative to the previously specified value. +10% -30% Except above items, specifications in clause 4.1~6 and 5.1 shall be satisfied.

 ALPS ELECTRIC CO., LTD.				
SYMB	DATE	APPD	CHKD	DSGD
		APPD. 1枝-2G '99.10.19 伊藤 啓	CHKD. 1枝-2G '99.10.19 林	DSGD. 1枝-2G '99.10.19 藤田
				TITLE ROTATIONAL ENCODER 回転形エンコーダ
				DOCUMENT NO. 5LA211-1CL (4/5)

CLASS No.	TITLE 回転形エンコーダ 規格書 ROTATIONAL ENCODER SPECIFICATION	(SW01)
-----------	---	--------

7. はんだ付け条件 Soldering conditions

7-1 手はんだの場合 Manual soldering

温度300°C以下、時間3秒以内
 Bit temperature of soldering iron : 300°C or less.
 Application time of soldering iron : within 3s.

7-2 ティップはんだの場合 Dip soldering

使用基板 : t1.6両面銅張銅板
 Printed wiring board: Both-sided copper clad laminate board with thickness of 1.6mm.

フラックス : 比重0.82以上のフラックスを用い発泡式フラクサーにて発泡面高さは、基板厚の3分の2。

Flux:
 - Specific gravity: 0.82 or more.
 - Flux shall be applied to the board using a bubble foaming type fluxer.
 - The board shall be soaked in the flux bubble only to the 2/3 of its thickness.

プリヒート : 基板表面温度100°C以下、時間2分以内
 Preheating:
 - Surface temperature of board: 100°C or less.
 - Preheating time: within 2 min.

はんだ : 温度260±5°C、時間5±1秒
 Soldering:
 - Solder temperature: 260±5°C.
 - Immersion time: within 5±1s.

以上の工程を1回または2回通過する。
 Apply the above soldering process for 1 or 2 times.

					ALPS ALPS ELECTRIC CO., LTD.			
					APPD. 1枝-2G 99.10.19 伊藤樹	CHKD. 1枝-2G 99.10.19 林	DSGD. 1枝-2G 99.10.18 喜瀬	TITLE ROTATIONAL ENCODER 回転形エンコーダ
							DOCUMENT NO. 5LA211-1CL	(5/5)
SYMB	DATE	APPD	CHKD	DSGD				

OR

(10/10)

CLASS NO.	TITLE プッシュモーメンタリスイッチ規格書 PUSH MOMENTARY SWITCH SPECIFICATION	(SW02)
-----------	---	--------

1. 定格容量 (抵抗負荷) D. C. 16V3A (10mA MIN)
Switch rating (Resistor load)
2. 電気的性能 Electrical characteristics

項目 Item	条件 Conditions	規格 Specifications
2-1 接触抵抗 Contact resistance	D. C. 5V10mA電圧降下法にて測定する。 Measured by the 10mA 5V D. C. voltage drop method.	100mΩ 以下 Less than 100mΩ
2-2 チャタリング Chattering	1サイクル (OFF-ON-OFF) 1秒で動作させる。 Switch is operated at the rate of 1 cycle 1 sec. The 1 cycle shall be OFF-ON-OFF.	10msec以下 Less than 10msec
2-3 絶縁抵抗 Insulation resistance	端子-軸受間にD. C. 250V1mA印加する。 Measurement shall be made under the condition which a voltage of 250VD. C. 1mA is applied between individual terminals and bushing.	端子-軸受間にて100MΩ以上 Between individual terminals and bushing: 100MΩ MIN.
2-4 耐電圧 Dielectric strength	端子-軸受間にA. C. 300V1分間又は、A. C. 360V2秒間印加する。(リーク電流1mA) A voltage of 300VA. C. shall be applied for 1min or a voltage of 360VA. C. shall be applied for 2sec between individual terminals and bushing. (Leak current:1mA)	損傷・アーク・絶縁破壊がないこと。 Without damage to parts arcing or breakdown.

注記: 軸・スイッチ端子間は絶縁されております。
Note: Shaft is insulated from switch terminal.

3. 機械的性能 Mechanical characteristics

項目 Item	条件 Conditions	規格 Specifications
3-1 スイッチ回路・接点数 Contact arrangement		単極単投 (Push on) S. P. S. T. (Push on)
3-2 スイッチ移動量 Switching stroke		1.5±0.5mm
3-3 スイッチ作動力 Switch operation force		5±2N

4. 耐久性能 Endurance characteristics.

項目 Item	条件 Conditions	規格 Specifications
4-1 寿命特性 Operating life	定格負荷にて軸を毎時500回の速さで20,000回連続動作を行う。 但し、試験途中5,000で中間測定を行う。 The shaft of switch shall be 20,000 times at a speed of 500times per hour with electrical load. after which measurements shall be made. However, an interim measurement shall be made immediately after 5,000 times.	接触抵抗: 200mΩ以下 その他、初期規格を満足すること。 Switch contact resistance: 200mΩMAX. Except above items, specifications in clause 2.2~4. and 3.1~3 shall be satisfied.

					TITLE PUSH MOMENTARY SWITCH プッシュモーメンタリスイッチ
					DOCUMENT NO. 5LA2114-5 (/)
SYMB	DATE	APPD	CHKD	DSGD	

APPD. 1枚-1G
99.9.1
大矢

DSGD. 1枚-1G
99.9.1
山口

OR